

AKU340

Bottom Port, Analog Silicon MEMS Microphone

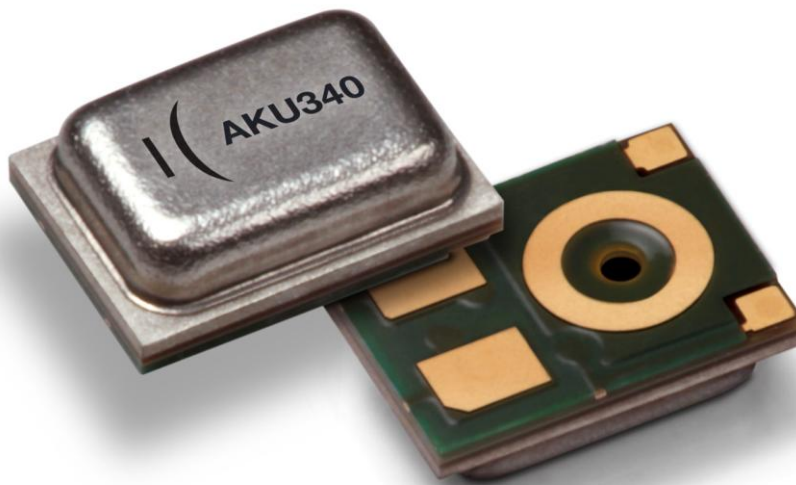

Datasheet

Part number(s)	AKU340
Package type	LGA, bottom port, metal lid
Data sheet revision	1.04
Release date	19 June 2015
Document number	DS26-1.04 AKU340 Data Sheet
Notes	Specifications are subject to change without notice. Product photos and pictures are for illustration purposes only and may differ from the real product's appearance.

AKU340

Analog, HD Voice Silicon MEMS Microphone

General Description

The AKU340 is an HD Voice quality, bottom port, analog output silicon MEMS IC microphone. It is an integrated circuit (IC) consisting of a MEMS acoustic sensor, a pre-amplifier, charge pump, and supporting circuitry in a spacing saving package footprint of 2.5 x 3.35 x 1.00 mm.

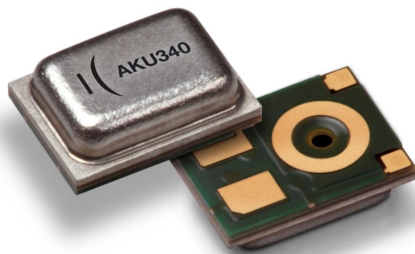

Designed specifically to meet the demanding requirements of mobile handset OEMs, the AKU340 offers excellent acoustic performance with 62dB signal-to-noise ratio (SNR), and tight sensitivity matching of just +/-2dB between microphones. It also offers a flat wideband frequency response, with less than 3dB variations from 60Hz to 12.5kHz, delivering uniform audio capture across a broad audio spectrum. The AKU340 metal lid package is immune to RF and Electromagnetic (EM) interferences, allowing for easy integration into wireless devices.

Key Features

- Bottom port, Analog output
- Omni-directional microphone
- High SNR: 62 dB
- Tight sensitivity tolerance: -38 dB +/- 2 dB
- Matched microphones in frequency and phase response for array applications
- Flat frequency response: +/- 3dB 60Hz – 12.5kHz
- Package immune to RF/EM interference
- Lead-free, surface-mountable and RoHS2 compliant
- Halogen-free in accordance with IEC61249-2-21
- Thin profile, SMT packaging
- Industry-standard, small form factor package of: 2.5 x 3.35 x 1.00 mm

Typical Applications

- Smartphones & Mobile handsets
- Tablet computers
- Speaker phones
- Digital still/video cameras
- Bluetooth & wired headsets
- Portable media players
- IC / digital voice recorders
- Gaming consoles / controllers
- Voice activated entertainments systems and remote controllers
- Smart-home sensor hubs / clusters, and IoT acoustic sensor nodes
- Microphone arrays – multi-mic applications and noise cancellation algorithms which benefit from microphones with tightly matched sensitivity and phase
- Other small, thin consumer electronic devices using more than one microphone

	AKU340 Analog Silicon MEMS Microphone	Data Sheet
---	---	------------

Index of Contents

1.	ABSOLUTE MAXIMUM RATINGS	4
2.	STANDARD OPERATING CONDITIONS	4
3.	ELECTRICAL AND ELECTRO-ACOUSTIC SPECIFICATIONS	4
4.	DEVICE CHARACTERISTICS	5
	4.1 Typical Frequency Response	
	4.2 I_{DD} vs. V_{DD}	
	4.3 Sensitivity vs. V_{DD}	
	4.4 Total Harmonic Distortion	
5.	PACKAGE	6
6.	PIN-OUT AND CONNECTION DIAGRAMS	7
	6.1 Pin Out	
	6.2 Schematic	
7.	MANUFACTURING NOTES	8-10
	7.1 Solder Reflow	
	7.2 Part Handling	
	7.3 PCB Land Pattern & Stencil Pattern	
8.	RELIABILITY SPECIFICATIONS	11
9.	PART MARKING INFORMATION	11
10.	PACKAGING INFORMATION	12
11.	ORDERING INFORMATION.....	12
12.	REFERENCE MATERIALS	13-14
	12.1 Application Notes	
	12.2 Theory of Operation	
	12.3 Measurement Guidelines	
	12.4 Glossary of Terms	
13.	DOCUMENT REVISIONS	14

	AKU340 Analog Silicon MEMS Microphone	Data Sheet
---	---	------------

1. ABSOLUTE MAXIMUM RATINGS

Supply Voltage, V_{DD} to GND	5.5V
ESD Tolerance	
Human Body Model	2000V
Machine Model	200V
Storage Temperature Range	-40°C to 105°C

2. STANDARD OPERATING CONDITIONS

Operating Temperature Range @ 2V	-40°C to 85°C
Supply Voltage (V_{DD})	1.6V to 3.6V

3. ELECTRICAL AND ELECTRO-ACOUSTIC SPECIFICATIONS

Unless otherwise noted, test conditions are:
 $V_{DD} = 2.0V$ $T_a = 25^\circ C$ $RH = 50\%$

Parameter	Test Conditions	Min.	Typ.	Max.	Unit
Directivity		Omni-directional			
Low Frequency -3dB			60		Hz
Upper Frequency +3dB			12.5		kHz
Signal to Noise Ratio (SNR)	$f_{in} = 1kHz$, A-weighted, 20Hz-10kHz, 0dB gain		62		dB
Sensitivity ¹	1kHz, 94dB SPL	-40	-38	-36	dBV/Pa
Total Harmonic Distortion (THD) ¹	@ 94dB SPL, $f_{in} = 1 kHz$			0.5	%
	@ 114dB SPL, $f_{in} = 1 kHz$			5	
Power Supply Rejection Ratio (PSRR)	100mVpp, $f = 217Hz$	60			dB
Current Consumption ¹	No load			300	μA
Output Impedance			150		Ω
Sensitivity loss across voltage	Change in sensitivity over 3.6V to 1.65V		0		dB
Polarity	Increasing sound pressure	Increasing output voltage			

Note 1: Parameter 100% tested

4. DEVICE CHARACTERISTICS

4.1 Frequency Response

(Measured frequency response normalized to 1kHz)

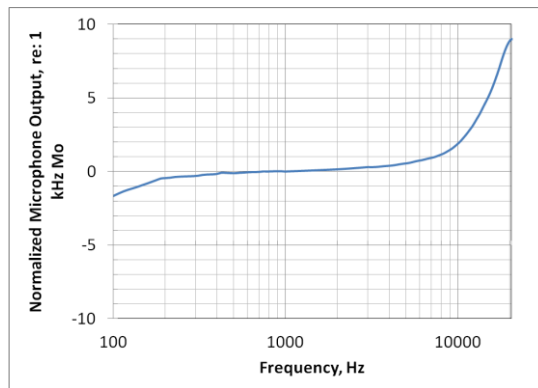

4.2 I_{DD} vs. V_{DD}

(Measured current consumption relative to supply voltage)

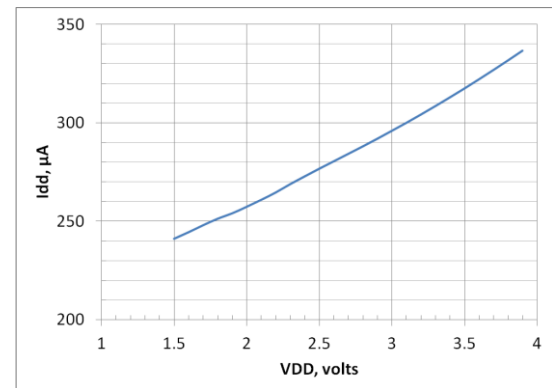

4.3 Sensitivity vs. V_{DD}

(Measured sensitivity changes relative to supply voltage)

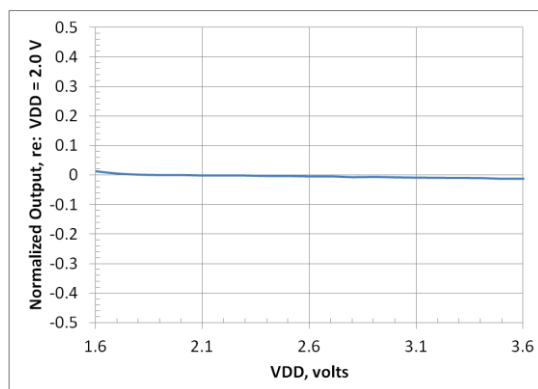

4.4 Total Harmonic Distortion

(Measured THD relative to speaker output pressure level)

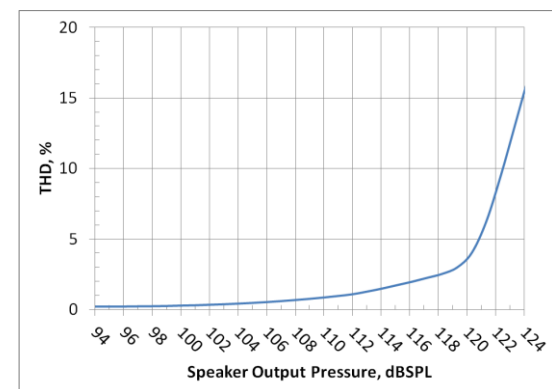

5. PACKAGE

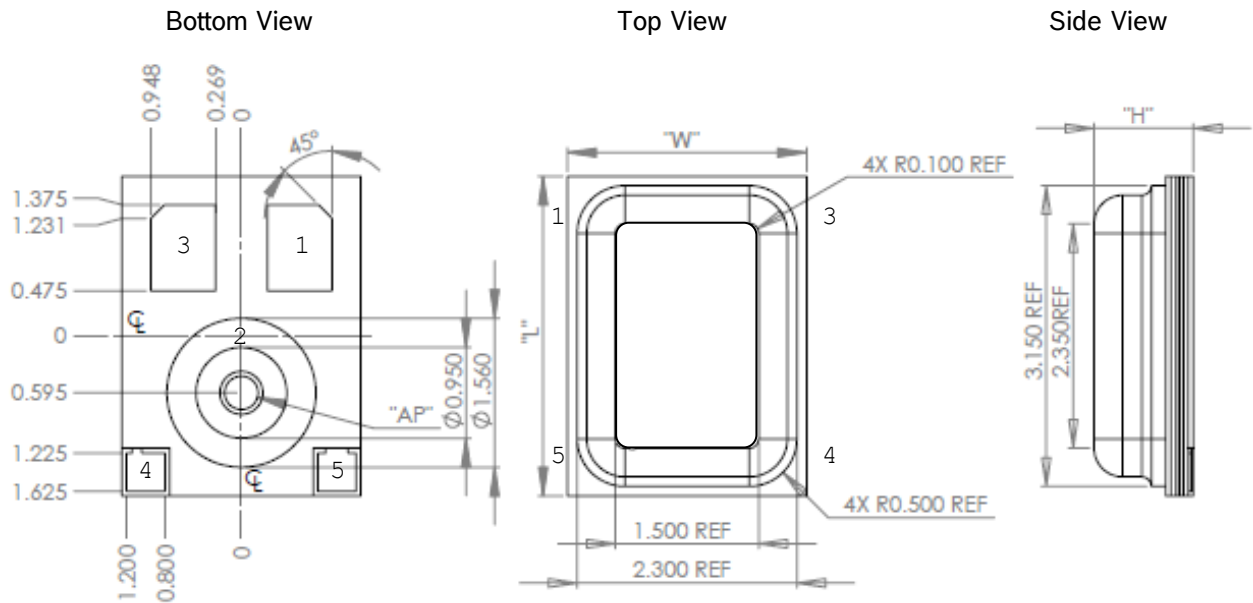

Item	Dimension	Tolerance	Units
Length (L)	3.35	± 0.10	mm
Width (W)	2.50	± 0.10	mm
Height (H)	1.00	± 0.10	mm
Acoustic Port (AP)	0.35	± 0.05	mm
Planarity	Top/Bottom	± 0.05	mm
All dimensions in mm Tolerance ± 0.05mm unless otherwise specified			

6. PIN-OUT AND CONNECTION DIAGRAMS

6.1 Pin-Out

(As viewed from **bottom** of package)

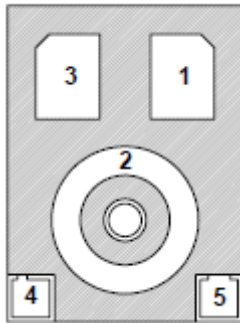

Pin	Name	Function
1	V _{OUT}	Analog output voltage
2	GND	Ground
3	V _{DD}	Power supply voltage for microphone
4	NC ¹	No Connect
5	NC ¹	No Connect

Note 1: Pins 4 & 5 can be connected to improve reflow manufacturability, but are not necessary. If used, Pins 4 & 5 should be tied to GROUND.

6.2 Typical Application Schematic

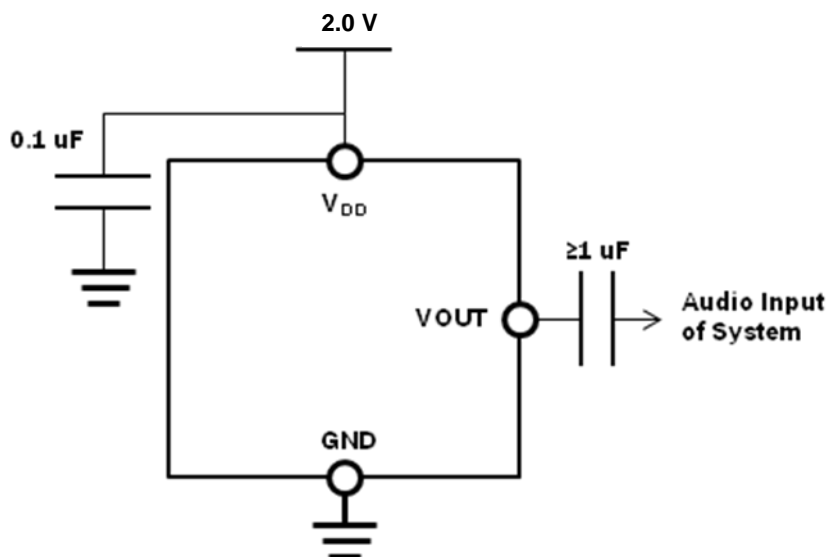

7. MANUFACTURING NOTES

7.1. Solder Reflow

Typical solder reflow profile

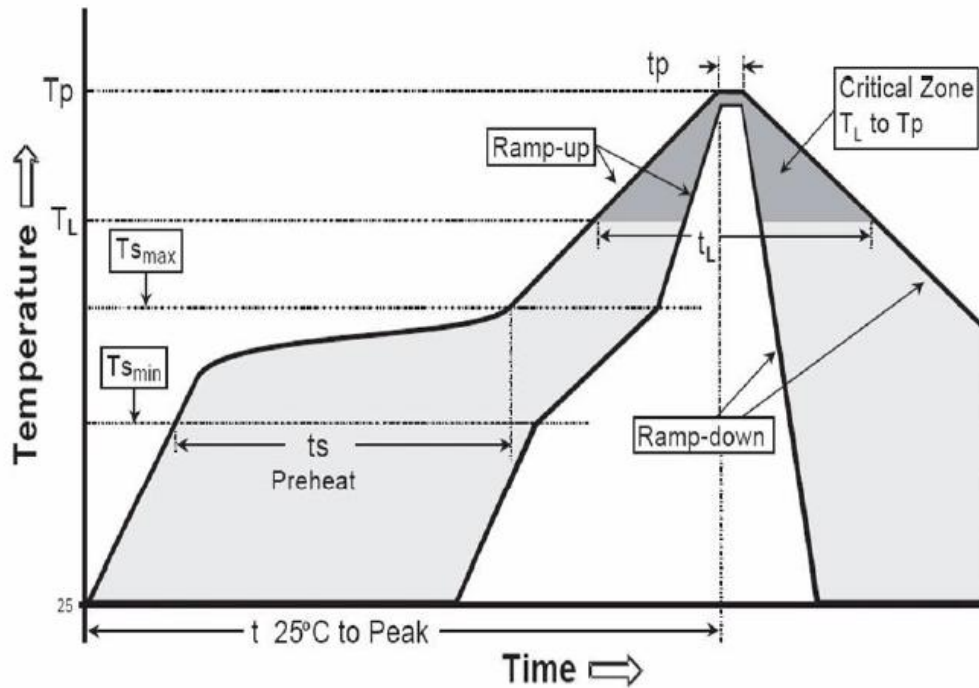

IPC-020c-5-1

Average ramp-up rate	max. 3°C/s
Time t_s between $T_{s_{min}}$ (150°C) and $T_{s_{max}}$ (200°C)	60s – 120s
Time t_L above liquidous temperature T_L (217°C)	60s – 90s
Peak temperature T_p	max. 260°C
Time t_p at T_p	max. 20s
Average ramp-down rate	max. 6°C/s

Note: It is recommended to fine-tune the reflow process to optimize for variations in materials, environment, handling, PCB board size and thickness, etc.

Please refer to AN60-Handling, Soldering, and Mounting Instructions for more detailed information and precautions.

	AKU340 Analog Silicon MEMS Microphone	Data Sheet
---	---	------------

7.2. Microphone Handling

Although the microphone may not appear damaged immediately due to inappropriate handling, there can be long term effects that affect the lifetime of the component.

Rule of thumb: The microphone is an artificial ear so treat it like your own ear.

- Do not blow air into the acoustic port of the microphone for any reason. Do not subject it to pressurized air
 - e.g. when cleaning the board or other components on the same board
- Do not apply vacuum to the acoustic port of the microphone
- Do not insert liquids
 - If populated circuit boards are washed, the microphone must be protected
- Do not insert dust
 - The production facilities must be clean
 - e.g. if PCB routing/sawing is done close to the microphone after SMT assembly and reflow
- Do not insert any objects
 - If assembly or rework is done manually, care must be taken that the tools cannot enter the mic sound port
 - It is best to choose tool size so that it does not fit through the sound port of the microphone
- Do not cover the acoustic port with tape when heating during assembly or reflow
- Do not apply extreme mechanical stresses on the microphone, including mechanical shocks above 10kG or compression of the microphone package.
- After a bottom port microphone has been assembled on a circuit board, protect the sound port (now on the other side of the board) from dust, liquids, and other foreign materials as well as any tools and pressurized air.

ESD Handling Procedures



Follow CMOS handling procedures with Akustica MEMS microphones. Handle the microphone with proper workplace grounding to include wrist straps and ionized airflow over open trays and reels of microphones. Do not hot-swap/hot-plug during testing. Device pins have ESD ratings of 2kV/200V for HBM/MM respectively.

7.3 PCB Land Pattern & Stencil Pattern

PCB Land Pattern Layout

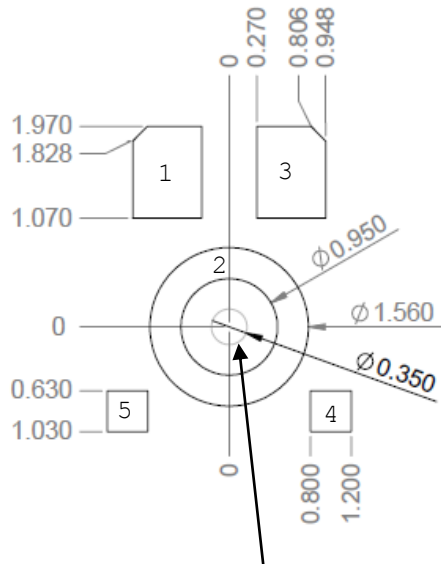

Acoustic port (PCB must be drilled here)

Suggested Solder Paste Stencil Pattern Layout

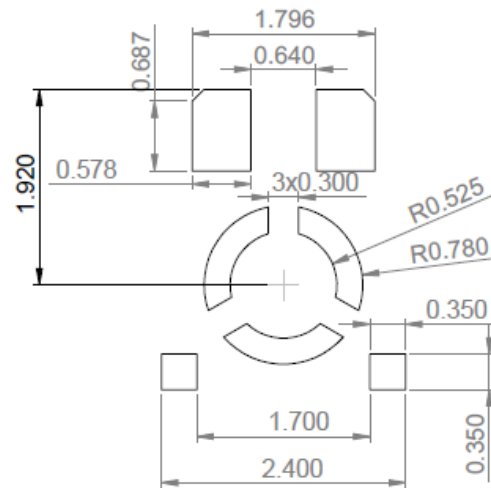

Note: Stencil printer settings will likely require minor optimizations when transferring this stencil pattern to a high volume production printer.

Please refer to AN60-Handling, Soldering, and Mounting Instructions for more detailed information and precautions.

	AKU340 Analog Silicon MEMS Microphone	Data Sheet
---	---	------------

8. RELIABILITY SPECIFICATIONS

The microphone sensitivity after stress must deviate by no more than 3dB from the initial value.

	Test	Test Condition
1	Cold Temp Operation	Temperature = -40°C, 1000 hours (with bias)
2	Hot Temp Operation	Temperature = 105°C, 1000 hours (with bias)
3	Humidity Operation	Temperature = 85°C, RH = 85%, 1000 hours (with bias)
4	Cold Temp Storage	Temperature = -40°C, 1000 hours (without bias)
5	Hot Temp Storage	Temperature = 105°C, 1000 hours (without bias)
6	Humidity Storage	Temperature = 85°C, RH = 85%, 1000 hours (without bias)
7	Thermal Cycle	100 Cycles, -40°C to +125°C, 15min soaks, <30sec ramps
8	Vibration	Sinusoidal Vibration, 20-2000Hz, 4min sweeps, 16min along each of 3 axis, amplitude 3 limits of 20G and 0.06"
9	Mechanical Shock	10,000G shocks, 5 impacts along each of 6 axes
10	Drop Test	Using 150gm aluminum fixture, 3 drops along each of 6 axes (total 18 drops) from 1.5m height onto concrete drop surface.
11	ESD (HBM)	+/-2000V, 1 discharge for each polarity, 11 pin combinations, 22 total discharges per microphone
12	ESD (MM)	+/- 200V, 1 discharge for each polarity, 11 pin combinations, 22 total discharges per microphone
13	ESD	+/- 8kV, contact discharge to lid with DUT grounded
14	Moisture Sensitivity Level	24 hour bake at 125°C, followed by 168 hours at 85°C, 85%RH, followed by 3 passes solder reflow (MSL Level 1)

9. PART MARKING INFORMATION



Line 1: A340X (A = Akustica, Part Code = 340, X = Assembly Facility)
 Line 2: WWYLL (WW = Work Week, Y = Year, LL= Lot Number Processed During Work Week)

10. PACKAGING INFORMATION

10.1 Tape Specification

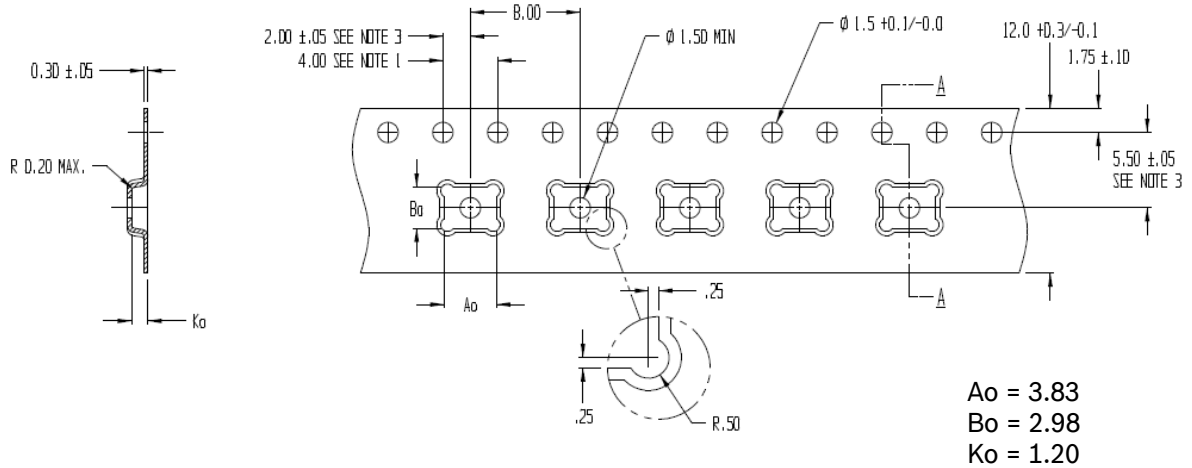



Notes:

1. 10 sprocket hole pitch cumulative tolerance +/-0.2
2. Camber in compliance with EIA-481
3. Pocket position relative to sprocket hole measured as true position of pocket, not pocket hole
4. A_o and B_o are calculated on a plane at a distance "R" above the bottom of the pocket

10.2 Component Orientation

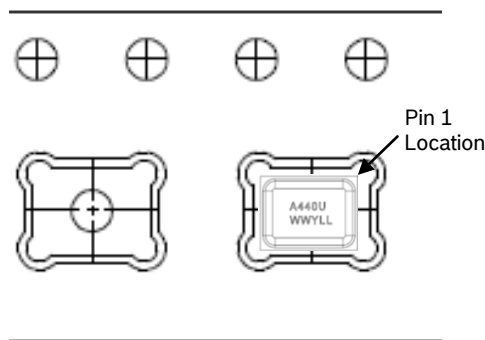
5.



	AKU340 Analog Silicon MEMS Microphone	Data Sheet
---	---	------------

11. ORDERING INFORMATION

Part Name	Order Number	Part Code	Package	Shipping Method	Standard Quantity
AKU340	02730A3401	A340	LGA	13" Reel	5,900

12. REFERENCE MATERIALS

12.1 Application Notes

AN60 - Handling, Soldering, and Mounting Instructions
 AN48 - AKU340 Coupon Board App Note

12.2 Theory of Operation

The AKU340 analog output microphone is a condenser microphone which has a structure consisting of a diaphragm (1) and a backplate (3), separated by an air gap (2), forming a parallel plate capacitor as shown. The nominal capacitance of the microphone can be determined by $C = \epsilon A/d$ where:

ϵ = the permittivity of free space
 A = area of the diaphragm
 d = airgap spacing

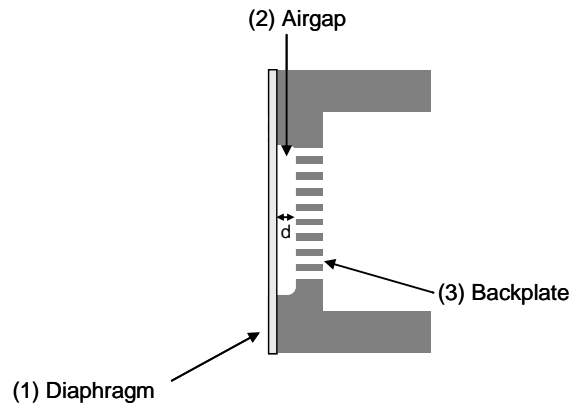

Sound pressure impinges on the diaphragm. The deflection of the diaphragm in response to sound causes the capacitance to vary. The variable capacitance is converted into an analog voltage signal which is amplified by the on-chip output amplifier.

12.3 Measurement Information

Measuring Signal to Noise Ratio

The Signal to Noise Ratio (SNR) is the ratio of the output due to a 1 kHz, 94 dB SPL input signal to the Noise Floor of the microphone. It is measured at the output of the on-chip output amplifier. To measure the noise floor, the microphone is placed in a sound isolation box. The power spectral density (PSD) is measured and A-weighted. The A-weighted PSD is integrated over the audio band. The square root of the integrated value is the output Noise Floor of the microphone. Both the SNR and Noise Floor are usually quoted in dB.

12.4 Glossary of Terms

A-weighting: The A-weighting filter is designed to approximate the variation in human ear sensitivity over the audio band at low sound pressure levels and is used to improve the correlation of a measured device noise level to the noise level perceived by the human ear.

	AKU340 Analog Silicon MEMS Microphone	Data Sheet
---	---	------------

dB (Decibel): A decibel (dB) is ten times the logarithm of a power ratio of two quantities. For linear quantities such as pressure and voltage, the decibel level is calculated using the formula $dB = 20 \cdot \log(\text{Value1}/\text{Value2})$. Value1 is usually a measured quantity and Value2 is usually a standard reference quantity that is measurement dependent. In order to calibrate a specification given in dB, you must know the reference value.

Frequency Response: The frequency response indicates the sensitivity of the microphone over a given frequency range.

12.4 Glossary of Terms (cont.)

Sound Pressure Level (SPL): The sound pressure level is an expression of loudness in dB SPL. The reference value is $20 \mu\text{Pa}_{\text{rms}}$ which is the lower threshold of hearing of a healthy human ear at 1 kHz. A sound pressure of $1 \text{ Pa}_{\text{rms}}$ corresponds to a sound pressure level of 94 dB SPL. As a reference, the sound pressure level of a noisy office environment would be roughly 75 dB SPL.

Power Supply Rejection Ratio (PSRR): The PSRR supplies a quantitative measurement of how ripples in the power supply voltage affect the output voltage of a component. It is calculated as the ratio of the power supply voltage change to the output voltage change of the component.

	AKU340 Analog Silicon MEMS Microphone	Data Sheet
---	---	------------

13. DOCUMENT REVISIONS

Rev. No	Description of modification/changes	Date
1.0	Updated for final. Released 1.0	30-Apr-13
1.01	Updated order numbers for new order code system, RoHS compliance to RoHS2. Added pin identification numbers	15-Oct-13
1.02	Edited cover page. Reformatted the part description / general description page (pg. 2). Updated AN60 footnote in section 7.	10-Feb-14
1.03	Updated headers	10-Oct-14
1.04	Updated ordering code table	19-Jun-14

Akustica, Inc.
2835 E Carson St. Suite 301
Pittsburgh, PA / USA 15203

sales@akustica.com
www.akustica.com

Modifications reserved | Printed in USA
Specifications subject to change without notice

Mouser Electronics

Authorized Distributor

Click to View Pricing, Inventory, Delivery & Lifecycle Information:

[Akustica:](#)

[AKU340](#)